

REVISIONS					
ZONE	REV.	DESCRIPTION	DATE	ECO NO.	APPROVED
	0	Initial Release	6/10/2013	1434	

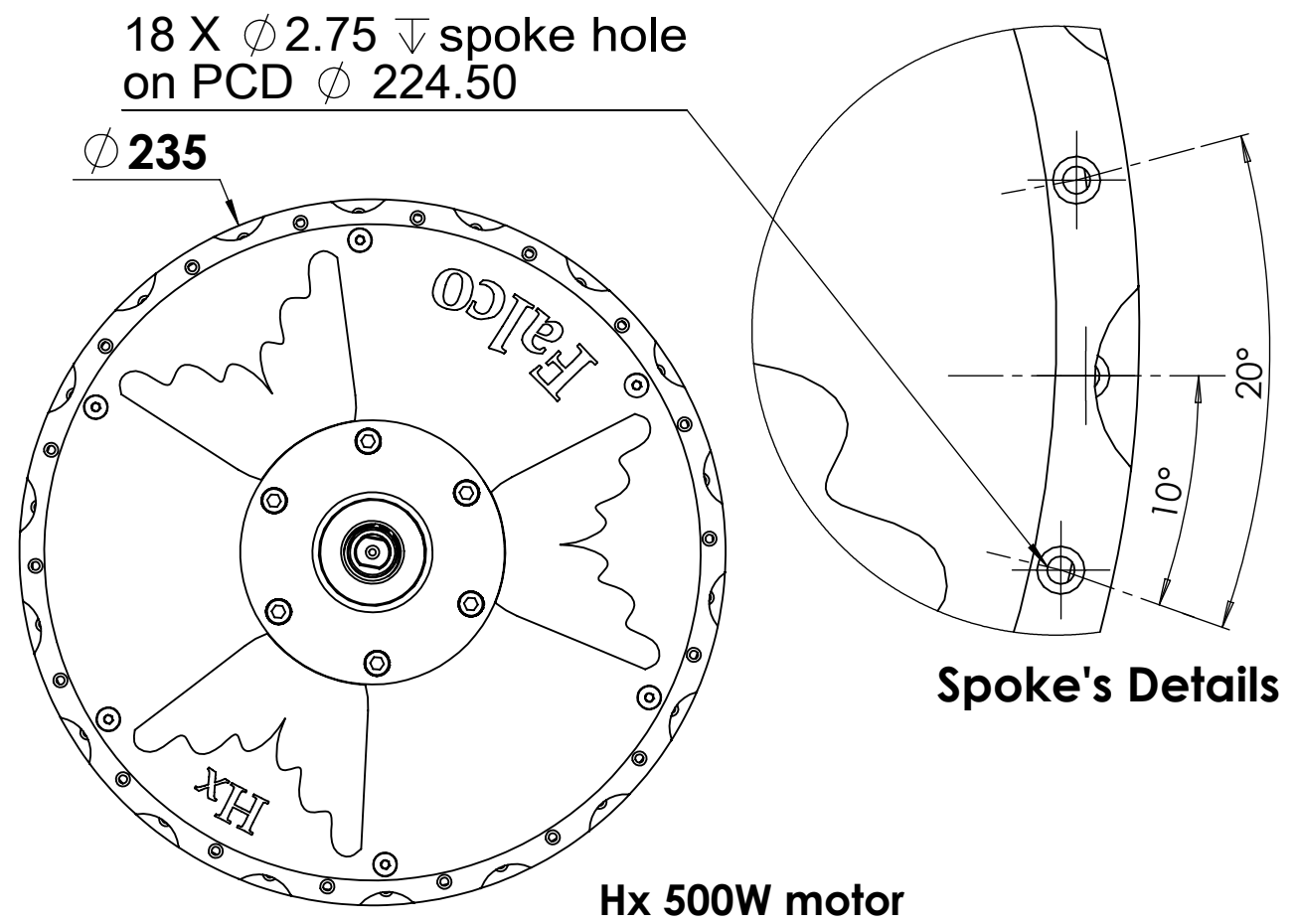
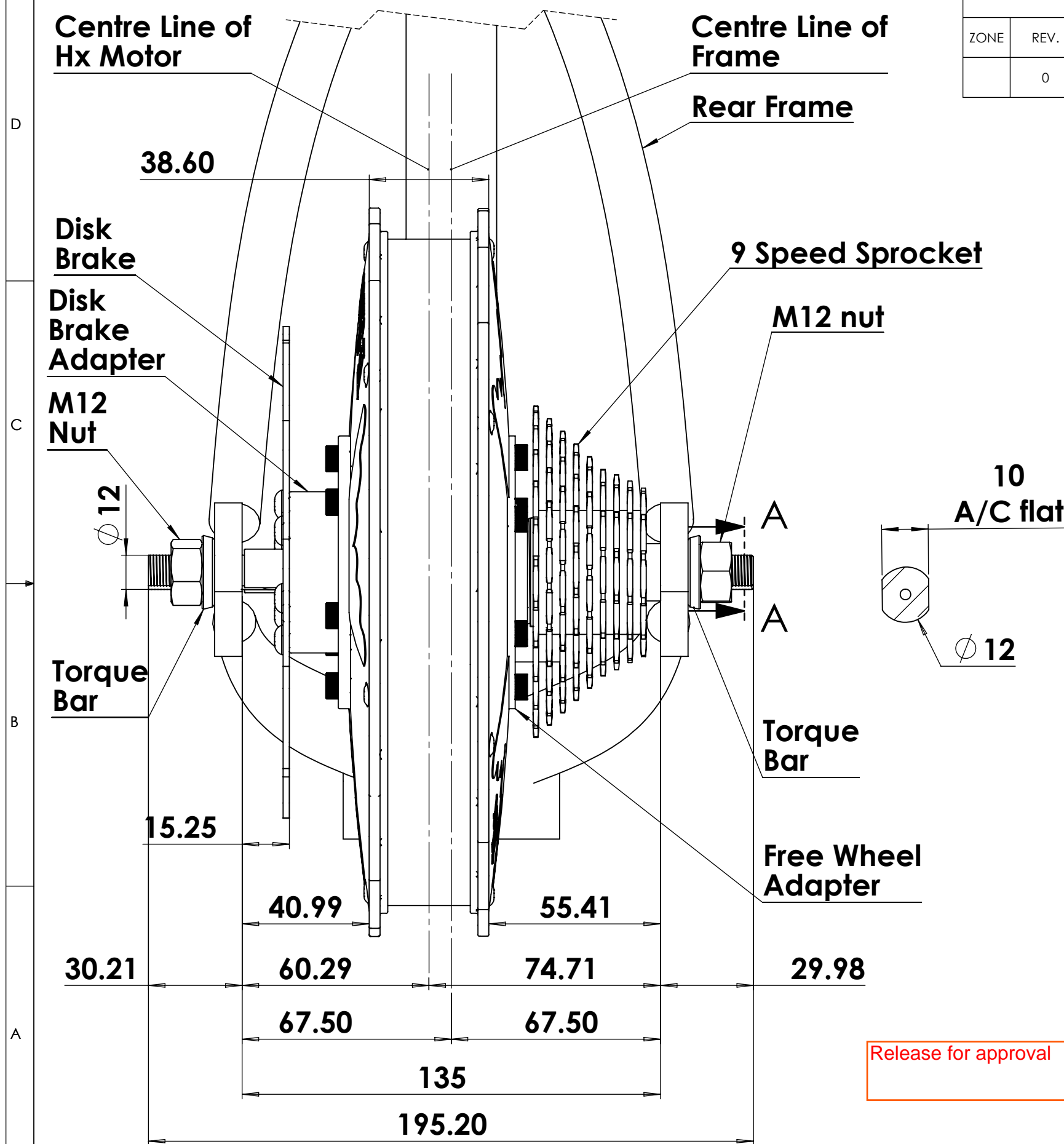

BOM for Rear Wheel Installation				
sr.no	Part number	Revision	Description	Qty
1.	500087	C	Disk Brake Adapter	1
2.	500089	C	Free wheel adapter	1
3.	500173	2	Spacer(35.5mm)	1
4.	500112	A	Torque bar	2
5.	500111	A	M12 Nut	2

UNLESS OTHERWISE SPECIFIED:		NAME	DATE	Falco eMotors Pvt. Ltd
DIMENSIONS ARE IN MM TOLERANCES: FRACTIONAL ± ANGULAR: MACH ± BEND ± TWO PLACE DECIMAL ± THREE PLACE DECIMAL ±		DRAWN	10/6/13	
INTERPRET GEOMETRIC TOLERANCING PER:		CHECKED	RKD	TITLE: Hx 500W Motor Rear Wheel Installation
MATERIAL		ENG APPR.		
FINISH		MFG APPR.	RYP	SIZE B DWG. NO. 100261 REV 0
DO NOT SCALE DRAWING		Q.A.		SCALE: 1:10 Wt: SHEET 1 OF 1
		Comments:		

Release for approval